

4

3

2

1

F

F

E

E

D

D

C

C

B

B

A

A

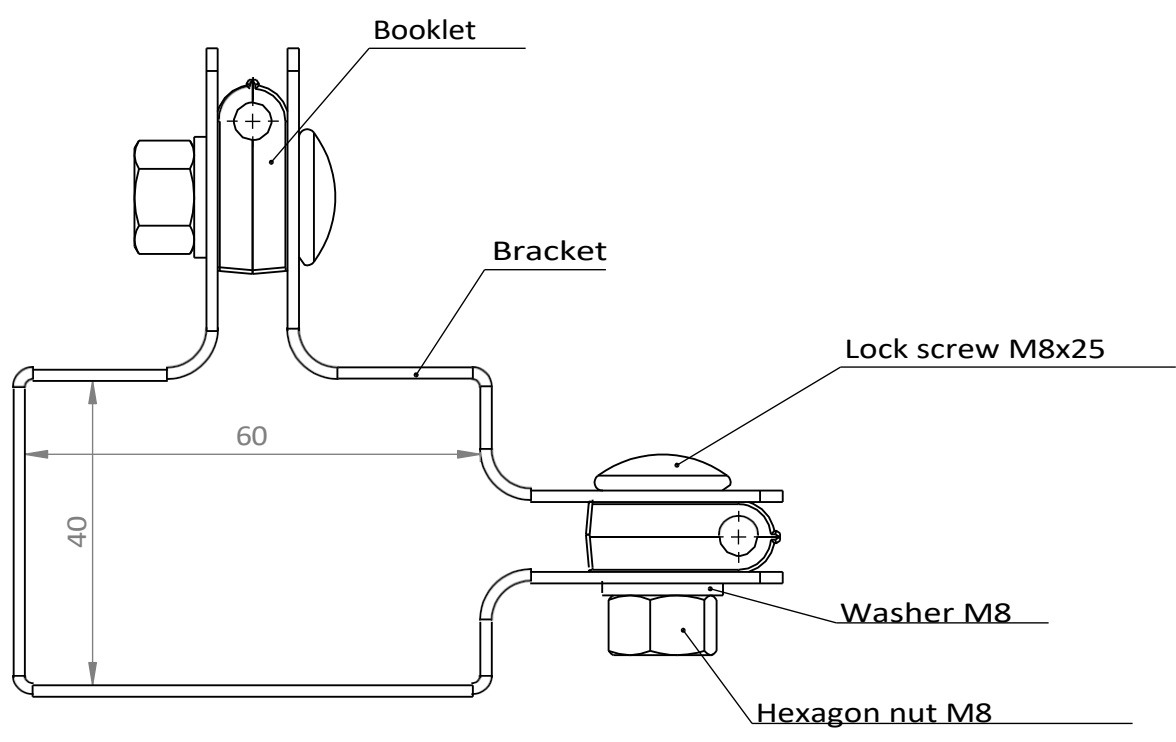

**Grid booklets available**



- $\varnothing 3$
- $\varnothing 4$
- $\varnothing 5$
- $\varnothing 6$

**Available colours (powder coating)**

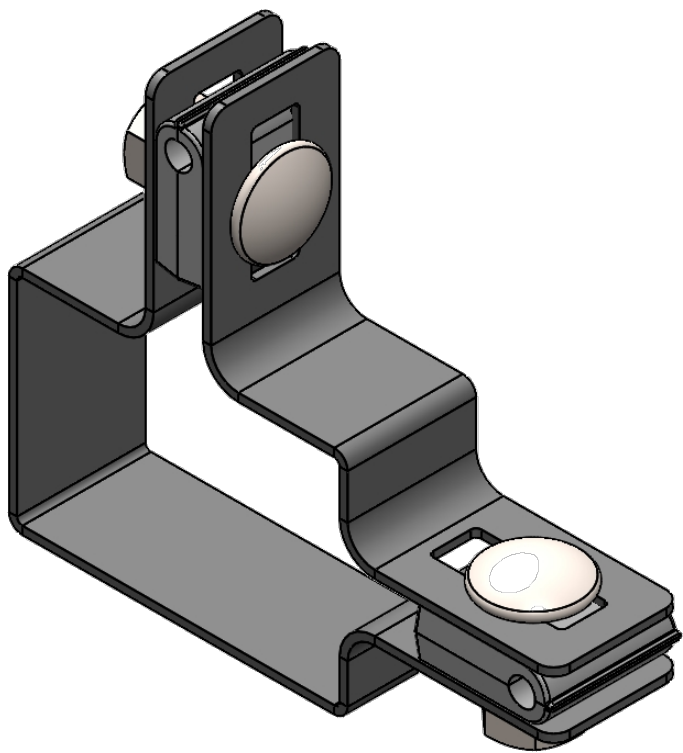
- Anthracite
- Black
- Brown
- Green
- White galvanised



**COPYING PROHIBITED**

 <small>All rights reserved</small> <small>All right reserved</small>	 <small>Print can be unscalded</small>	Standard:	A4 format	Scale 1:1	Sheet 1/1
		Material Bracket Booklet	Weight [kg]	Heat treatment	Principal
Constructor	31.01.2025	Drawing name			
He drew	03.02.2025	<b>60x40 angle post clamp</b>			
Checked	04.02.2025	Name of assembly/appliance 04.02.2025			Drawing no.
Issued	3	2		1	

4

1